

ProFacere

Lego-Like RMT

RECONFIGURABLE MACHINE TOOL



ACADEMIC SPIN-OFF
University of Genoa
University Federico II of Naples



Contacts:
Ivan Rosciano: 333 5096923
Alessandro Bruzzone: 320 7982141

info@profacere.com
facebook.com/profacere
www.profacere.com

ProFacere s.r.l.

Legal address: via Galata 37/8, 16121 Genoa, IT
VAT Registration N. 02569770999

Startup, technology and advantages of Lego-like RMT

ProFacere s.r.l. is a spinoff of the Universities of Genova and Naples; it was recently established (15th November 2018) and registered as innovative startups in the special sections of the Register of Companies created ad hoc at the Chambers of Commerce (<http://startup.registroimprese.it/isin/home>).

ProFacere s.r.l. starts from an invention developed at the University of Genoa.

The invention allows to overcome the constraint of the linear drive systems, currently used in machine tools, and theoretically extend the stroke of the axes in an infinite modular way.

The idea already obtained national awards, ranking first at the twelfth edition of Bernardo Nobile Prize in 2016; the invention is protected by two patent applications, one international (WO2017/137938) already in the National Phases in India, China, Japan, USA, Canada and European Patent, and an Italian one (102017000137650) under international extension (PCT/EP2018/083045); the patents applications were filed by the University of Genoa that owns the industrial rights.

ProFacere s.r.l. will transfer innovation to the manufacturing industry and to institutional trainers by manufacturing modular machine tools that combine in a reconfigurable and scalable system both the Industry 4.0 technologies along with the conventional ones.

The Lego-like Reconfigurable Machine Tools (RMT), which will be manufactured by ProFacere s.r.l., are based on the innovative linear drive that allows the reconfiguration of the machine tool with reduced times and costs. The innovation consists in the inversion of the roles of the screw and nut device used in linear drives; in this way it is possible to design a modular machine tools system with scalable work volume. This solution permits also to easily configure machine tool with different technologies such as milling, turning, 3D printing, thermal cutting, laser scanning, etc.

The proposed technology reduces the investments destined to the equipment capital while assuring the same level of capacity of machine tools currently on the market, **thanks to its flexibility and reconfigurability.**

Furthermore, the modularity and standardization of the components of Lego-Like RMT system enable a new manufacturing business model based on sharing machine tools between companies in the same district, with an additional reduction in assets invested in machine tools.

MODULAR ELEMENTS

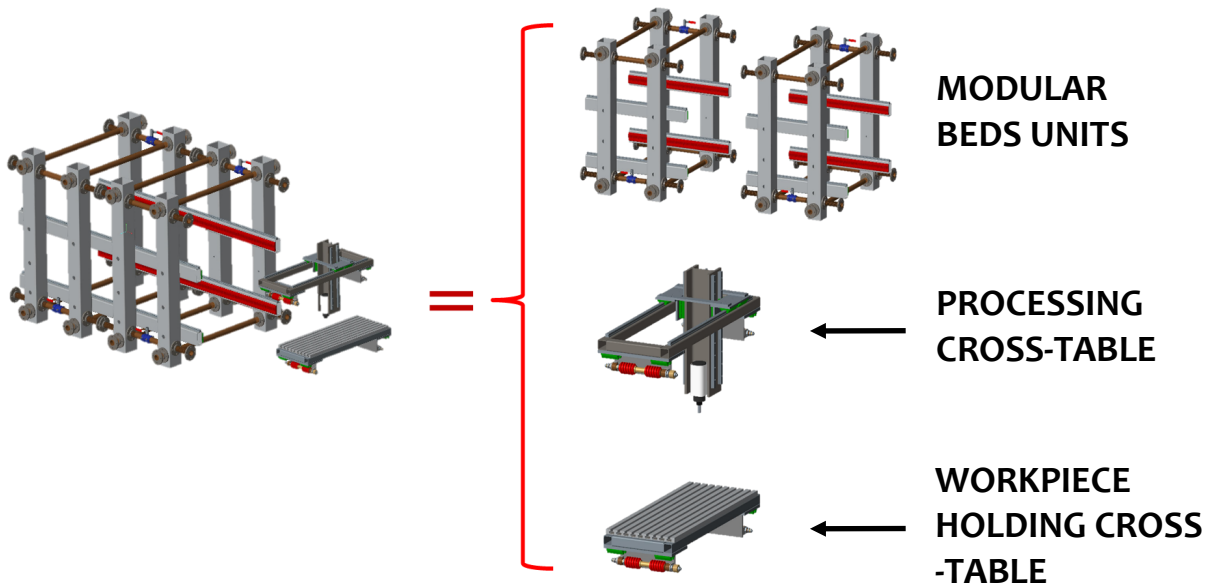

● What is a Lego-Like RMT?

RMT stands for Reconfigurable Machine Tools and defines a machine tools that can be easily modified, by changing its configuration in order to provide different processing technologies or modify the dimension of the working volume with few, simple and quick steps. The Lego-Like RMT made by combining modular units: bed units (frame structures) and cross-tables that can host workpiece-holders or processing devices (e.g. electro-spindles or other operating apparatuses); these units can be organized to perform different types of operations even on the same beds line.

● How does a Lego-Like RMT work?

The units of the Lego-Like RMT are standardized, autonomous and modular: it is therefore possible to configure the machining system according to specific needs. For example, it is possible to:

- change the working volume, by varying the number of installed bed units
- increase or reduce the number of parallel operations by varying the number of cross-tables
- change the type of processing, using standard or custom cross-tables hosting different processing technologies.

● What can be done with a Lego-Like RMT?

- **Serial processing**, using the Lego-Like RMT as a serial manufacturing line performing a sequence of different operations on the workpiece conveyed along the line by one cross-table (several processing cross-tables operating sequentially of the workpiece);
- **Parallel processing**, performing simultaneous identical operations on several workpieces carried by cross-tables on the same Lego-Like RMT line in order to decrease production times (several processing cross-tables operating in parallel on several workpieces);
- **Machining very large parts**, by exploiting the modularity of the structural frames (beds) to augment the main axis length of the machine, supporting the parts with many workpiece holding cross-tables.

There are no limits to the versatility of the Lego-Like RMTs, which can operate by combining different modular elements, with maximum flexibility.

LEGO-LIKE RECONFIGURABLE MACHINE TOOLS

TOOLING, FLEXIBILITY AND INDUSTRY 4.0

- Lego-Like RMT is a manufacturing system where technologies and operations performed on workpieces can be changed simply and instantaneously.

This goal has been achieved thanks to the invention described in the patent applications **WO2017/137938**, already in national phase in India, China, Japan, USA, Canada and EP, and the Italian patent application **102017000137650** now in the PCT international stage PCT/EP2018/083045.

- The Lego-Like RMT is an autonomous manufacturing system, which can be configured according to the user needs. Lego-Like RMTs can be controlled through G-code, to program the tools path and set the machining process parameters.
- Each cross-table is an autonomous sub-system of the Lego-Like RMT dedicated to 1) the execution of one particular operation (on the processing cross-tables) or 2) move of the workpiece during machining (on the workpiece holding cross-tables).
- The Lego-Like RMT is remotely operable: through internet, as well as intranet, it is possible to load G-code part programs, give commands and view the status of the jobs. A remote alarm system guarantees security for unmanned operations. These characteristics fulfill industry 4.0 model.

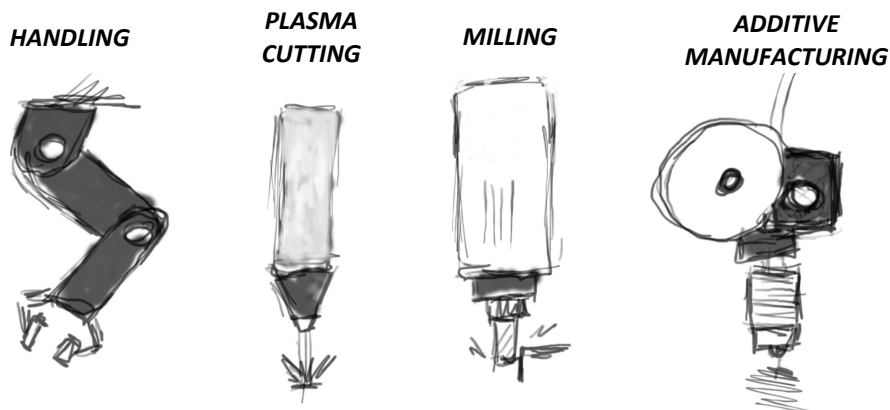

- Many processing technologies can be hosted on the Lego-Like RMTs, including:
 - metal cutting (milling up to 5 axes, turning),
 - thermal cutting and laser technologies,
 - additive manufacturing (FDM printing)
 - welding,
 - handling by robotized arms

Thanks to its characteristics, the Lego-like RMT is a versatile system able to offer the best solutions for different manufacturing needs. Due to its underlying idea, the Lego-like RMT integrates a transport system: the main axis of the machine is a guideway for both the machining operations, carried out by the processing cross-table, and for moving the machined workpieces along the line between the processing cross-tables.

LEGO-LIKE RECONFIGURABLE MACHINE TOOLS

MODULARITY AND ACTUATION SYSTEM

- The invention at the origin of the Lego-like RMT, claimed in the patent application **WO2017/137938**, relates to an innovative linear actuation axis. Precisely, the roles assigned to the screw and nut in the driving mechanisms used in current machine tools have been reversed. In this way it is possible to have a translation axis with "unlimited" length, which can be modularly extended according to the work requirements.

The system is suitable for high precision movements and for the transmission of high forces, it guarantees excellent stiffness in the case of metal cutting processes while also providing high translation speeds for those technologies characterized by low reaction forces (additives, thermal cutting, laser scanning, handling, etc.) while requiring fast and accurate positioning.

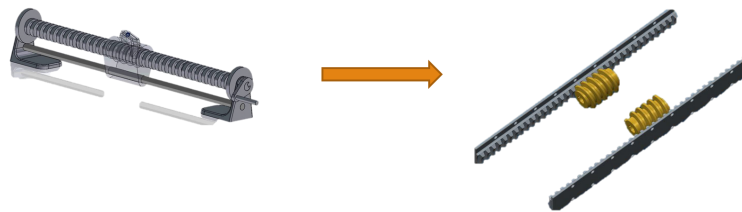

- The **handling system** with worm screw racks uses modular bed units with length multiple of the screw pitch, so that there is a precise connection between adjacent units. This characteristic permits the rotational and translational motion of the driving screw, hosted by the cross-table, along contiguous bed units' racks. In this way each cross-table can be driven along the whole length of the RMT line. The positioning accuracy along the drive axis is guaranteed by feedback control.

Each modular bed unit is equipped with two pairs of worm screw racks which form two guideways, upper and lower, along which the processing and workpiece holding cross-tables can move, each cross-table being equipped with screws coupled to the racks.

Differently from the conventional linear drive mechanisms, such as rack and pinion, ball and screw, lead screw nut, the new drive mechanism of the Lego-Like RMTs is irreversible and consequently axial locking devices are not required.

Furthermore, the new drive does not contain components that induce an electromagnetic field that may be incompatible with certain materials or processing technologies.

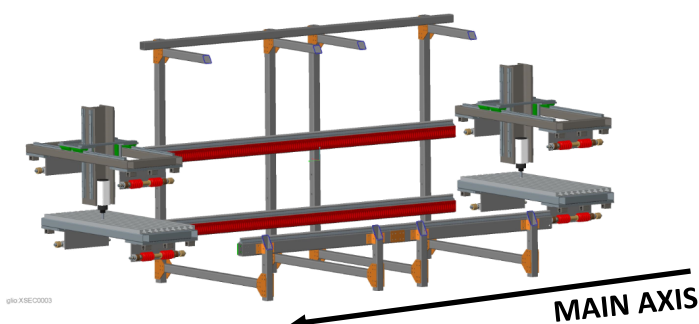

LEGO-LIKE RECONFIGURABLE MACHINE TOOLS BEDS MODULES

- The structural design was made by exploiting the know-how of university team experts in the field of machining and FEM analysis. The machine tool frame structure guarantees high static and dynamic stiffness.

The closed frame design guarantees maximum rigidity of the single bed module, making it suitable for metal cutting operations (milling, drilling, turning) under heavy conditions.

Since 2017 two prototypes have been developed in order to evaluate the feasibility of the project. The main features of the commercial Lego-Like RMT model are:

- ◆ Dimensions: 1000x1200mm, according to EUR2 pallet standard
- ◆ Height of the module equal to 1600mm, variable upon explicit request of the customer
- ◆ Machining precision in peripheral milling with a 3.5 kW spindle: 0.05 mm
- ◆ Rapid installation of the modular units, rapid reconfigurability
- ◆ Cutting oil and compressed air distribution lines integrated in the modular units
- ◆ Anti-vibration dampers and levelling feet
- ◆ Electrified tracks to supply the boards
- ◆ Linear encoders for active feedback control of the cross-tables along the main axis

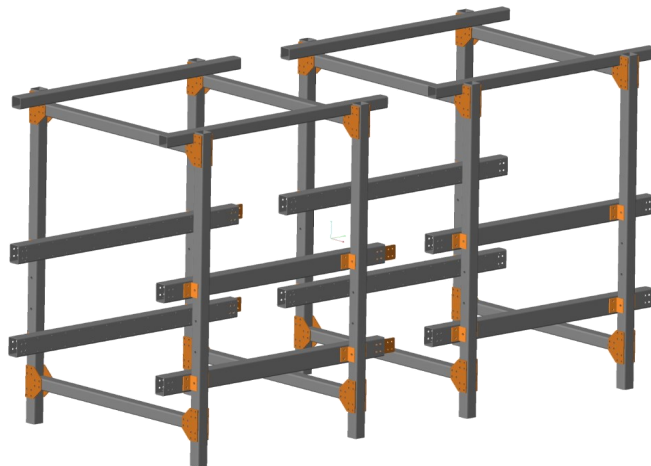

LEGO-LIKE RECONFIGURABLE MACHINE TOOLS

MODULAR CROSS-TABLES

- The cross-tables are designed as autonomous and independent systems with a modular approach:
 - ◆ Each cross-table comes from a basic set-up, which includes movement along the main axis of the RMT, the hardware and software necessary for the control as well as a basic frame.
 - ◆ Modular elements can be installed later to permit to customize the functionality to the basic cross-table, by adding kinematics for moving the processing tool or for supporting the workpiece.

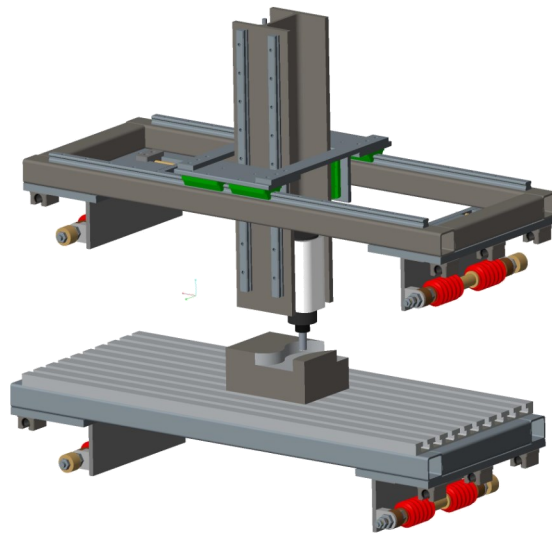

- **Main cross-tables features:**

- ◆ Driving screws on the two sides of the table, for a correct distribution of torques and forces between the screws coupled and the racks
- ◆ Robust frame, pre-drilled to easily host transverse axes or T-slotted tables
- ◆ Integrated hardware and software control system and motors drivers to interface the line system monitor of the Lego-like RMT.

LEGO-LIKE RECONFIGURABLE MACHINE TOOLS CONTROL SYSTEM

● **Hardware and software**

The RMT Lego-like manufacturing system will be controlled by open source software running on low cost hardware boards. Currently the control system architecture is under development. The preliminary project includes:

~~Raspberry PI 3+ boards that communicate wireless and Arduino Mega cards equipped with shield to control the drivers of the axes motors of the RMT system;~~



one Raspberry PI 3+ system, monitor, for each line consisting of several modular beds units, to provide the interface between the user in the job shop, or with users remotely connected and the Lego-Like RMT system; the monitor connects the user with the processing and workpiece holding cross-tables in the line;

on each processing or workpiece holding cross-table, a Raspberry PI 3+ board, table controller, is wirelessly interfaced with the monitor and via cable with the Arduino Mega and its shield and drives to control the cross-tables motors.

The control system software is open source in order to allow users' customization. In particular it is based on:



multiple agent control, to coordinate resources in the Lego-like RMT system (cross-tables and beds units);

an RGLB firmware on each Arduino Mega board to interpret the G-code blocks of the part programs received via cable from the Raspberry PI 3+ table controller, and

an HTML web server for each line; the server runs on the Raspberry PI 3+ monitor card.

After the tests phase more technical details will be available.

The figures shown on the following pages indicate possible logical scalable configurations built using Lego-Like RMTs units.

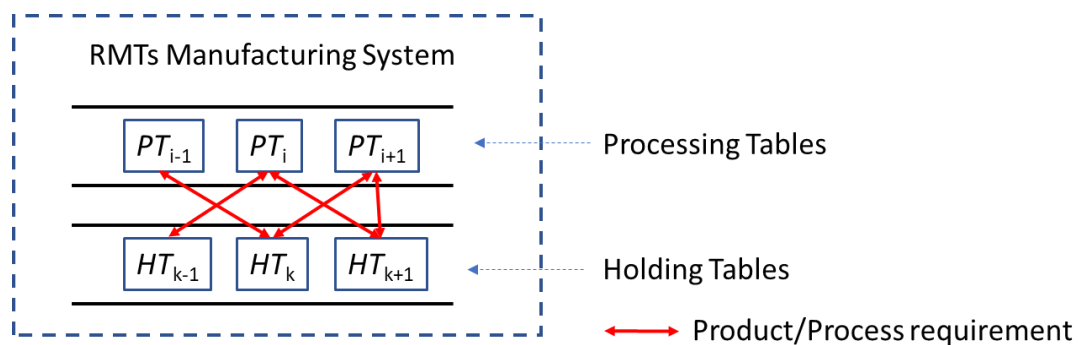

Logical Configuration of the control System

PT: Processing cross-Table

HT: workpiece Holding cross-Table

LEGO-LIKE RECONFIGURABLE MACHINE TOOLS CONTROL SYSTEM

● Lego-Like RMTs cluster (logical scheme)

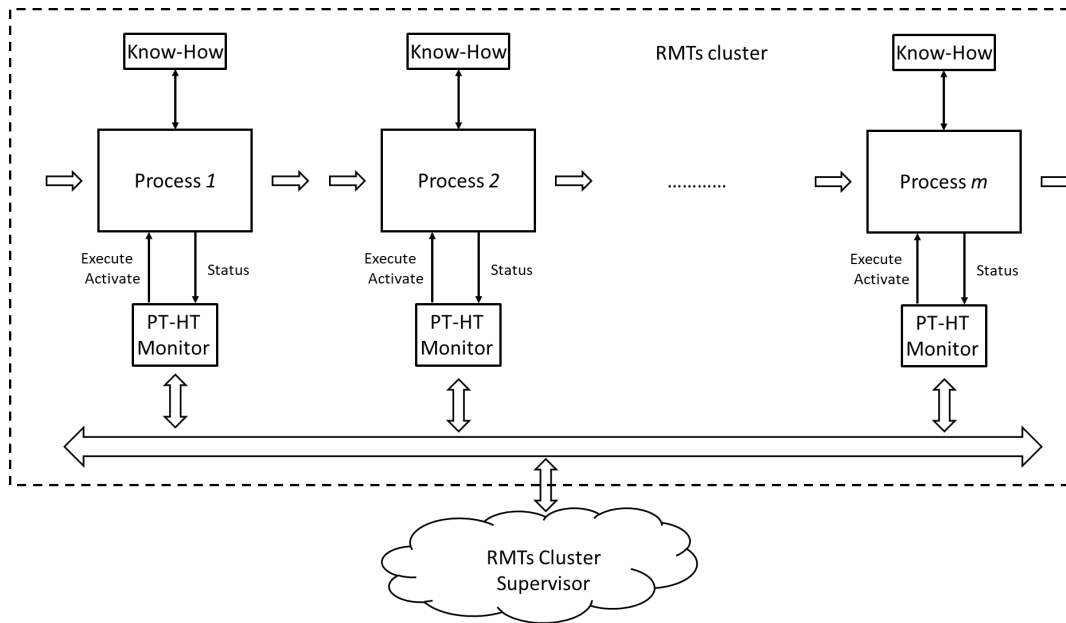

● Local reconfigurable Manufacturing Eco-System

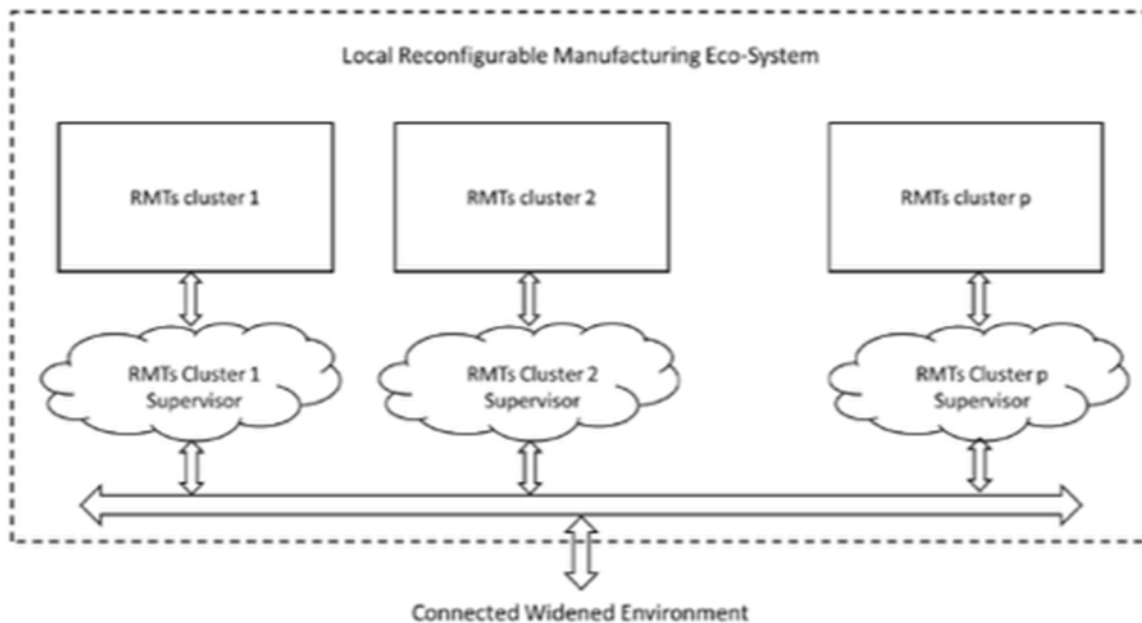

LEGO-LIKE RECONFIGURABLE MACHINE TOOLS

RESEARCH AND DEVELOPMENT

Further information on the Lego-Like RMT manufacturing systems ~~have been published and presented~~ in:

- ◆ A.A.G. Bruzzone, D.M. D'Addona, 2017, New perspectives in manufacturing: an assessment for an advanced reconfigurable machining system, 11th CIRP Conference on Intelligent Computation in Manufacturing Engineering, 19-21 July 2017, Ischia, Italy
- ◆ D.M. D'addona, A.A.G. Bruzzone, 2017, Lego-like reconfigurable machining system: New perspectives to optimize production capacity, IEEE 15th International Conference of Industrial Informatics INDIN'2017, 24-26 July 2017, Emden, Germany
- ◆ A.A.G. Bruzzone, D.M. D'Addona, 2017, A new reconfigurable machine tool architecture for technologies integration and cooperative capacity sharing, Technical talk, STC-O section of the CIRP General Assembly, 25 August 2017, Lugano, Switzerland



The Lego-Like RMT system has been designed according to the results provided by a Finite Elements Model analysis in order to limit the maximum displacement considering peripheral milling operations with a spindle of 3.5 kW.

